

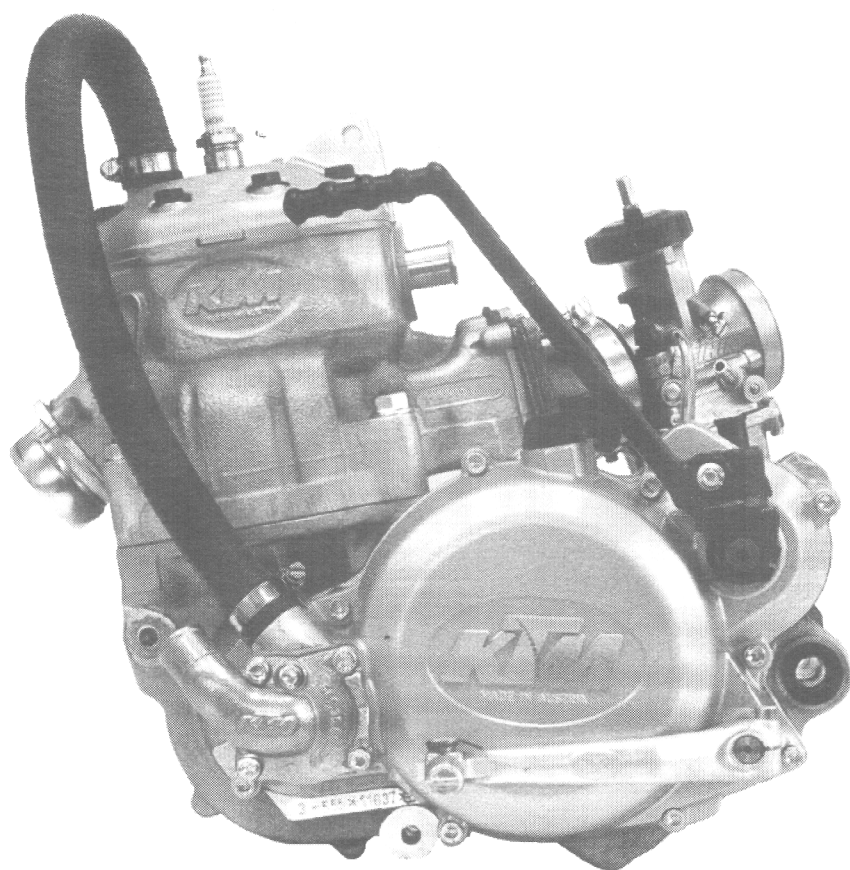

# ERSATZTEILKATALOG

## MOTOR 440/550 '94

Technische Daten



# SPARE PARTS MANUAL

## ENGINE 440/550 '94

Technical Data

ART. NR. 3.203.67

11.93

94-565.30.0 MOTORGEHÄUSE 440/500/550 '94  
ENGINE CASE

3, 4, 5, 6, 7, 9, 10, 11, 013, 13 • GETRIEBELAGER  
Transmission bearings  
Roulements transmission

BILD FIG.	TEILENUMMER PART NUMBER	BEZEICHNUNG DESCRIPTION	STK. QTY.
1	565.30.000.544	MOTORGEHÄUSE KPL.M.LAGER ENG.CASE CPL.W.B. 440/500	'92 1
1	565.30.200.144	MOTORGEHÄUSE KPL.M.LAGER ENG.CASE CPL.W.B. 550	'92 1
5	501.30.027.000	PASSHÜLSE 19 X 15,5 X 12 DOWEL	1
6	510.30.026.100	PASSHÜLSE 17 X 14 X 12 DOWEL	1
7	501.30.010.000	GEHÄUSEBÜCHSE CRANK CASE BUSH	2
9	565.33.028.000	ZWISCHENRADWELLE INTERM.GEAR PIVOT	1
10	0912 080163	ISK-SCHRAUBE DIN912-M8X16 A H SCREW	1
11	565.30.017.000	HALTEBLECH RETAINING PLATE	1
12	565.33.025.000	ANSCHLAGBLECH STOP PLATE	1
13	0991 060203	ISK-SENKSCHAUBE DIN7991-M6X20 FLAT HEAD BOLT	3
013	502.34.021.000	FEDERBOLZEN SPRINGBOLT	1
14	500.30.026.000	PASSHÜLSE 9X11,8X15 DOWEL	2
15	565.30.022.000	ENTLÜFTUNGSSTUTZEN DURCHM.10 BREATHER SCREW	1
16	543.07.018.001	SCHLAUCH 12 X 16 PER METER HOSE 12 X 16	0,3
17	565.30.039.000	MOTORGEHÄUSEDICHTUNG ENGINE CASE GASKET	1
18	580.38.020.000	ÖLABLASSSCHRAUBE MIT MAGNET M12 OIL DRAIN PLUG	1
19	580.38.022.000	DICHTRING 12 X 18 X 1,5 CU SEAL RING	2
019*	0910 120153	VERSCHLUSSSCHRAUBE M12X1,5 SW13 PLUG	1
019	0908 120153	VERSCHLUSSSCHRAUBE M12X1,5 PLUG	X
20	565.30.001.300/90	KUPPLUNGSDECKEL SILBER '89 CLUTCH COVER CPL.	1
21	565.30.025.375	KUPPLUNGSDECKEL-DICHTUNG 0,75 CLUTCH CASE GASKET	1
22	543.30.020.000	ÖLEINFÜLLSCHRAUBE PLUG	1
23	0770 160030	O-RING 16 X 3 O-RING	1
24	0760 172870	WELLENDICHTRING 17X28X7B RADIAL SEAL RING	1
25	0760 142460	WELLENDICHTRING 14 X 24 X 6 B SEAL RING	1
27	565.35.001.300	WASSERPUMPENDECKEL WATERPUMP COVER	1
28	565.35.003.300	PUMPENDECKELDICHTUNG WATER PUMP GASKET	1
29	0603 062101	DICHTRING 6,2X10X1 SEAL RING	1

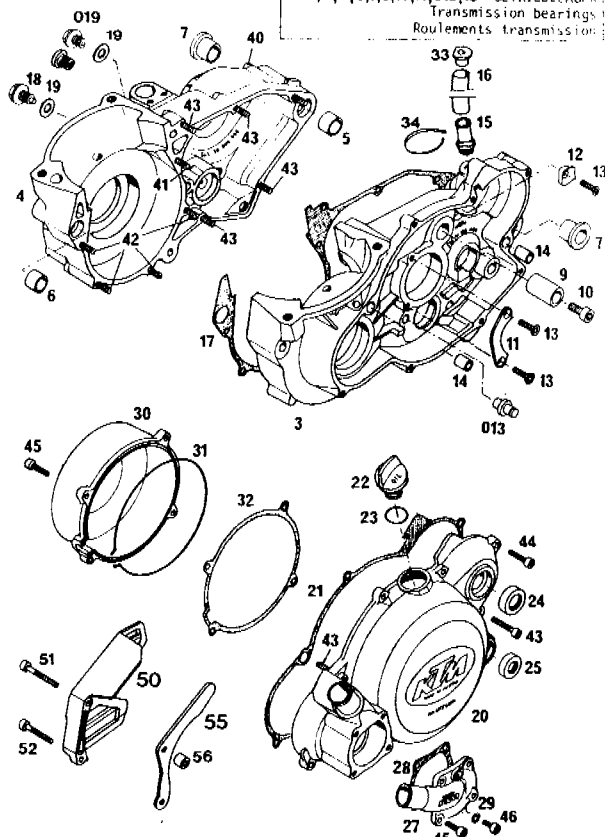

30	565.30.002.100/90	ZÜNDUNGSDECKEL SILBER IGN.CASE COVER	'89 1
31	565.30.002.150	MOOSGUMMISCHNUR 2MM GASKET	1
32	555.30.002.150	ZÜNDGEHÄUSEDICHTUNG 1,5 MM IGN. CASE GASKET	1
33*	441.06.018.000	KUNSTSTOFFKAPPE PLASTIC CAP	1
34*	440.11.076.305	KABELBAND 305MM PLASTIC BAND	1
40	0912 060753	ISK-SCHRAUBE DIN912-M6X75 A H BOLT	1
41	0912 060653	ISK-SCHRAUBE DIN912-M6X65 A H BOLT	1
42	0912 060503	ISK-SCHRAUBE DIN912-M6X50 A H SCREW	4
43	0912 060353	ISK-SCHRAUBE DIN912-M6X35 A H BOLT	6
44	0912 060253	ISK-SCHRAUBE DIN912-M6X25 A H SCREW	7
45	0912 060203	ISK-SCHRAUBE DIN912-M6X20 A H SCREW	8
46	0912 060103	ISK-SCHRAUBE DIN912-M6X10 A H SCREW	1
50	545.30.060.000	KETTENABDECKUNG VORNE CHAIN GUARD	1
51	0912 060453	ISK-SCHRAUBE DIN912-M6X45 A H BOLT	1
52	0912 060403	ISK-SCHRAUBE DIN912-M6X40 A H SCREW	1
55	545.30.047.014	KETTENDÄMPFUNGSBLECH 15-Z CRANK CASE PROTECT	1
55	545.30.047.013	KETTENDÄMPFUNGSBLECH 14-Z CRANK CASE PROTECT	1
56	545.30.047.000	DISTANZROLLE 7 X 12 X 9,5 BUSHING	2
--	565.30.100.000	DICHTUNGSSATZ 350-550 GASKET SET	1

\* = NEUTEILE / NEW PARTS

X = NACH BEDARF / AS REQUIRED

94-565.30.2 KURBELTRIEB 440/550 '94  
CRANKSHAFT, PISTON

BILD FIG.	TEILENUMMER PART NUMBER	BEZEICHNUNG DESCRIPTION	STK. QTY.
1*	565.30.418.000	KURBELWELLE 70 MM HUB 440 '94 CRANKSHAFT 440	1
1	565.30.218.000	KURBELWELLE 82 MM HUB 550 CRANKSHAFT 550	1
2	565.30.215.044	PLEUELAGER-REP.SATZ 350-550 CONN.ROD REPAIRKIT	1
3	565.30.234.000	NADELAGER 20X24X23 NEEDLE BEARING	1
4	0888 050650	SCHEIBENFEDER 5 X 6,5 WOODRUF KEY	1
5	0888 030050	SCHEIBENFEDER DIN6888-3X5 WOODRUFF KEY	1
6	565.30.081.000	AUSGLEICHSCHIEBE 36X48X0,10 SHIM	X
6	565.30.081.100	AUSGLEICHSCHIEBE 36X48X0,15 SHIM	X
6	565.30.081.300	AUSGLEICHSCHIEBE 36X48X0,30 SHIM	X
8	565.30.123.000	ZYLINDERROLLENLAGER NJ207 ROLLER BEARING	2
10	0760 325271	WELLENDICHRING 32X52X7B SEAL RING	1
11	0760 305272	WELLENDICHRING 30X52X7BTSL RADIAL SEAL RING	1
12	543.30.029.000	FEDERSCHIEBE B12X22 SPRING WASHER	1
13	510.30.028.100	BUNDMUTTER M12X1 LINKS MAGNETO NUT	1
14	560.30.048.000	SICHERUNGSBLECH 21X40X1 WASHER	1
15	0936 200155	SK-MUTTER DIN936-M20X1,5 H H NUT	1
20	565.30.007.000	KOLBEN KPL. 89 MM 440/500 CC PISTON CPL. 89,00	1
20	565.30.207.000	KOLBEN KPL. 92,25 MM 550 CC PISTON CPL. 92,25	1
21	565.30.032.000	KOLBENRING 89X1,25 440/500 CC PISTONRING 89X1,25	2
21	563.30.032.002	KOLBENRING 92,25X1,25 550 CC SQUARE RING 92,25	2
22	563.30.033.000	KOLBENBOLZEN 20X12X52,4 WRIST PIN	1
23	563.30.074.000	DRAHTSPRENGRING A20 RETAINING CLIP	2
30	0471 120010	SEEGERRING DIN471-12X1 CIRCLIP	1
31	0625 060016	RILLENKUGELLAGER 6001 RSR BEARING	2
32	0084 040063	ZYLINDERSCHRAUBE DIN84A-M4X6 FIL.HEAD SCREW	1
33	0125 050003	SCHEIBE DIN125-A5,3 FLAT WASHER	1
34	0760 152472	WELLENDICHRING 15X24X7 A-DUO SEAL RING	1
35	544.35.010.000	WASSERPUMPENWELLE WATER PUMP SHAFT	1



BILD FIG.	TEILENUMMER PART NUMBER	BEZEICHNUNG DESCRIPTION	STK. QTY.
36	565.35.005.300	WASSERPUMPENRAD PUMP ROTOR	1
37	0021 050003	SCHEIBE DIN9021-A5,3 FLAT WASHER	1
38	0912 050123	ISK-SCHRAUBE DIN912-M5X12 A H SCREW	1

\* = NEUTEILE / NEW PARTS      X = NACH BEDARF / AS REQUIRED

94-565.30.3 ZYLINDER 440/550 '94  
CYLINDER

BILD FIG.	TEILENUMMER PART NUMBER	BEZEICHNUNG DESCRIPTION	STK. QTY.
1*	565.30.405.000	ZYLINDER 89 MM CYLINDER	440'94 1
1	565.30.205.100	ZYLINDER 92,25 MM CYLINDER	550 91/92 1
2	565.30.030.000	ZYLINDERFUSSDICHTUNG 0,2 MM CYL. BASE GASKET	X
2	565.30.030.100	ZYLINDERFUSSDICHTUNG 0,3 MM CYL. BASE GASKET	X
2	565.30.030.200	ZYLINDERFUSSDICHTUNG 0,5 MM CYL. BASE GASKET	X
3*	0835 100453	STIFTSCHR.DIN835-M10X45-10.9 STUD	4
3*	0835 100503	STIFTSCHR.DIN835-M10X50-10.9 STUD	4
4	0331 100003	BUNDMUTTER M10 SW15 NUT	4
5	565.30.006.300	ZYLINDERKOPF CYLINDER HEAD	440/550 1
5	565.30.206.000	ZYLINDERKOPF 550 CC CYLINDER HEAD	1
6	565.30.036.000	ZYLINDERKOPFDICHTUNG CYL. HEAD GASKET	1
7	565.30.079.000	SONDERSCHRAUBE M8X42-10.9 SPECIAL SCREW	8
8	565.30.080.000	CU-SCHEIBE 8X16X1 WASHER	8
10	563.30.051.044	MEMBRANGEHÄUSE KPL. REED VALVE CASE	1
11	563.30.051.000	MEMBRANGEHÄUSE LOSE REED VALVE CASE	1
12	563.30.052.000	MEMBRANE REED VALVE	2
13	563.30.053.000	ANSCHLAGBLECH STOP PLATE	2
14	0084 040083	ZYLINDERSCHRAUBE DIN84A-M4X8 CYL.HEAD SCREW	8
15	555.30.054.000	MEMBRANEINSATZ VELOCITY INSERT	1
015	0982 550133	SK-BLECHSCHR.DIN7982-B5,5X13 SHEET-METAL SCREW	2
16	565.30.050.500	ANSAUGSTUTZEN KEIHIN VERG. '92 INTAKE ADAPTER	1
17	565.30.061.000	SHELLE 60/12 CLAMP	1
20	543.05.073.000	AUSPUFFFLANSCH EXH.FLANGE	1
21	544.30.046.000	AUSPUFFFLANSCHDICHTUNG EXHAUST GASKET	1
22	510.05.074.000	FEDERLASCHE RETAINING PLATE	1
32	544.35.025.000	FORMSCHLAUCH 18 X 25 - 130GRAD PREF.RAD.HOSE	1
33	100.01.020.000	SCHLAUCHBINDER A2 CLAMP	2
40	0912 060253	ISK-SCHRAUBE DIN912-M6X25 A H SCREW	6

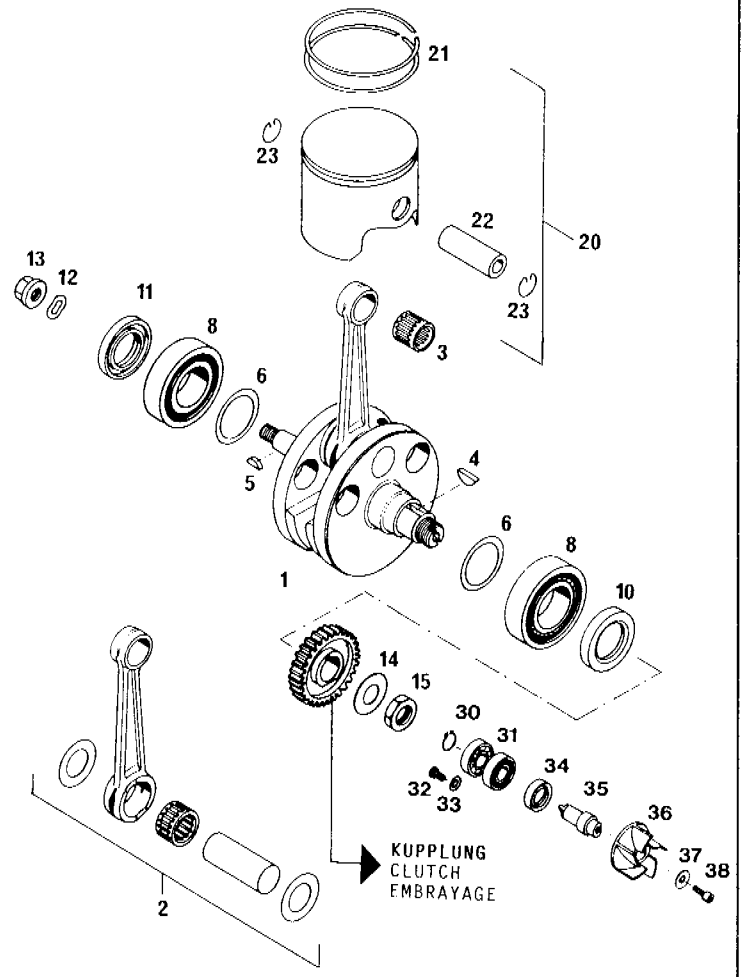

BILD FIG.	TEILENUMMER PART NUMBER	BEZEICHNUNG DESCRIPTION	STK. QTY.
41	0912 060203	ISK-SCHRAUBE DIN912-M6X20 A H SCREW	3
43	0137 060000	FEDERSCHEIBE DIN137-B6 SPRING WASHER	9
50*	546.30.021.000	ABLASSSCHRAUBE M10X1 PLUG	1
51	580.38.032.100	CU - DICHRING 8,2 X 12 X 2 SEAL RING-CU	1
60	0984 100163	ISK-SCHRAUBE M10X16 A H SCREW	1
61	580.38.032.010	DICHRING 10 X 14 X 1 CU SEAL RING	X
65	0933 060103	SK-SCHRAUBE DIN933-M6X10 H H SCREW	1
66	580.36.065.000	DICHRING 6 X 10 X 1 CU SEAL RING	1

\* = NEUTEILE / NEW PARTS      X = NACH BEDARF / AS REQUIRED

94-565.31.0 VERGASER KEIHIN PWK 39 '94  
CARBURETTOR

BILD FIG.	TEILENUMMER PART NUMBER	BEZEICHUNG DESCRIPTION	STK. QTY.
1*	565.31.701.244	VERGASER KEIHIN PWK39 CARBURETTOR 440 SX/EXC EUROPA 85 / 45 / 180 / R1368J II	130993 1
1*	565.31.701.344	VERGASER KEIHIN PWK39 CARBURETTOR 440 MXC/EXC USA 85 / 52 / 185 / R1466J II	140993 1
1*	565.31.701.444	VERGASER KEIHIN PWK39 CARBURETTOR 550 MXC USA 85 / 50 / 185 / R1363N III	150993 1
2*	546.31.245.000	STARTKOLBEN KPL. STARTER VALVE CPL.	1
3*	546.31.209.000	SCHWIMMER R-39 FLOAT CPL.	1
4*	546.31.211.000	SCHWIMMERGEHÄUSE FLOAT CHAMBER BODY	1
5	545.31.610.000	DICHTUNG SCHWIMMERGEHÄUSE SEAL FLOAT CHAMBER	1
6	545.31.699.000	VERSCHLUSSSCHRAUBE M18X1 PLUG 18X1	1
7	0770 180230	O-RING 2,3 X 18 X 22,6 O-RING	1
8*	546.31.220.000	SCHWIMMERNADEL FLOAT VALVE CPL.	1
9	545.31.612.000	HALTER D 7 BRACKET D 7	2
10*	545.31.607.042	LEERLAUFDÜSE GR.42 KEIHIN PILOT JET 42	X
10*	545.31.607.045	LEERLAUFDÜSE GR.45 KEIHIN PILOT JET	1
10*	545.31.607.048	LEERLAUFDÜSE GR.48 KEIHIN PILOT JET 48	X
10*	545.31.607.050	LEERLAUFDÜSE GR.50 KEIHIN PILOT JET 50	1
10*	545.31.607.052	LEERLAUFDÜSE GR.52 KEIHIN PILOT JET 52	1
10	545.31.607.055	LEERLAUFDÜSE GR.55 KEIHIN PILOT JET 55	1
11*	545:31.633.168	DÜSENNADEL R 1368 J KEIHIN JET NEEDLE	1
11*	545.31.634.063	DÜSENNADEL R 1363 N KEIHIN JET NEEDLE	1
11*	545.31.633.166	DÜSENNADEL R 1366 J KEIHIN JET NEEDLE	1
11*	545.31.634.165	DÜSENNADEL R 1465 J KEIHIN JET NEEDLE	1
11*	545.31.634.166	DÜSENNADEL R 1466 J KEIHIN JET NEEDLE	1
12	545.31.629.000	KLEMMFEDER NEEDLE CLIP	1
13*	546.31.235.006	GASSCHIEBER 6 THROTTLE VALVE	1
14*	546.31.232.000	NIPPEL CABLE HOLDER	1
15*	546.31.227.000	VERGASERDECKEL TOP PLATE	1

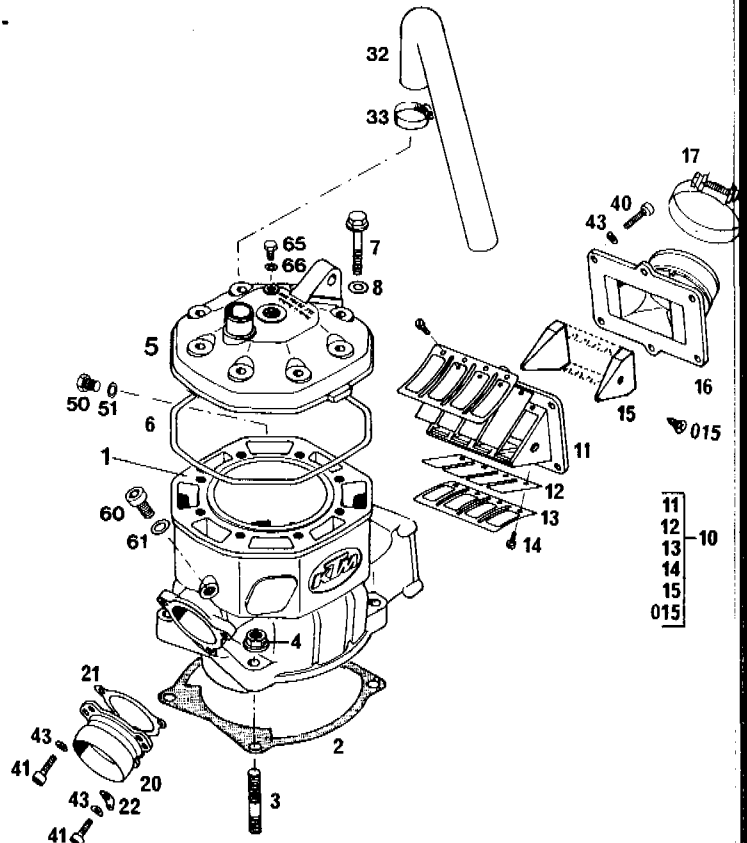
\* = NEUTEILE / NEW PARTS X = NACH BEDARF / AS REQUIRED



BILD FIG.	TEILENUMMER PART NUMBER	BEZEICHUNG DESCRIPTION	STK. QTY.
16	545.31.628.000	GUMMIDICHTRING 40 X 46 X 1 RUBBER SEAL RING	1
17	545.31.617.000	STELLSCHRAUBE ADJUST SCREW	1
18	545.31.615.000	FEDER SPRING	1
19*	546.31.230.000	SCHIEBERFEDER SPRING THROTTLE	1
20	545.31.621.000	KLAMMER CLAMP	1
21	0985 040153	LINSENSCHRAUBE DIN7985-M4X15 LENS HEAD SCREW	4
22	310.07.007.001	SCHLAUCH 5 X 8 PER METER BREATHER HOSE 5X8	0,96
23	520.31.137.001	PVC-SCHLAUCH 3X6 (ÜBERLAUF) TUBE 3X6	0,39
24	545.31.608.000	STIFT 2,5 X 25 SPINDLE 2,5 X 25	1
25	545.31.696.000	KLAMMER 6 MM CLAMP	3

94-565.31.0 VERGASER KEIHIN PWK 39 '94  
CARBURETTOR

BILD FIG.	TEILENUMMER PART NUMBER	BEZEICHUNG DESCRIPTION	STK. QTY.
26	545.31.623.170	HAUPTDÜSE GR.170 KEIHIN MAIN JET 170	X
26	545.31.623.175	HAUPTDÜSE GR.175 KEIHIN MAIN JET 175	X
26	545.31.623.180	HAUPTDÜSE GR.180 KEIHIN MAIN JET 180	1
26*	545.31.623.185	HAUPTDÜSE GR.185 KEIHIN MAIN JET 185	1
26*	545.31.623.190	HAUPTDÜSE GR.190 KEIHIN MAIN JET 190	X
27	545.31.625.000	STELLSCHRAUBE M6X0,75 CABLE ADJ. SCREW	1
28	520.31.126.000	SK-MUTTER M6X0,75 NUT	1
29*	546.31.219.000	STELLSCHRAUBE M5X30 ADJUSTING SCREW	1
30	0934 050003	SK-MUTTER DIN934-M5 HEX NUT	1
31*	546.31.231.000	FEDERTASSE COLLAR	1

\* = NEUTEILE / NEW PARTS X = NACH BEDARF / AS REQUIRED

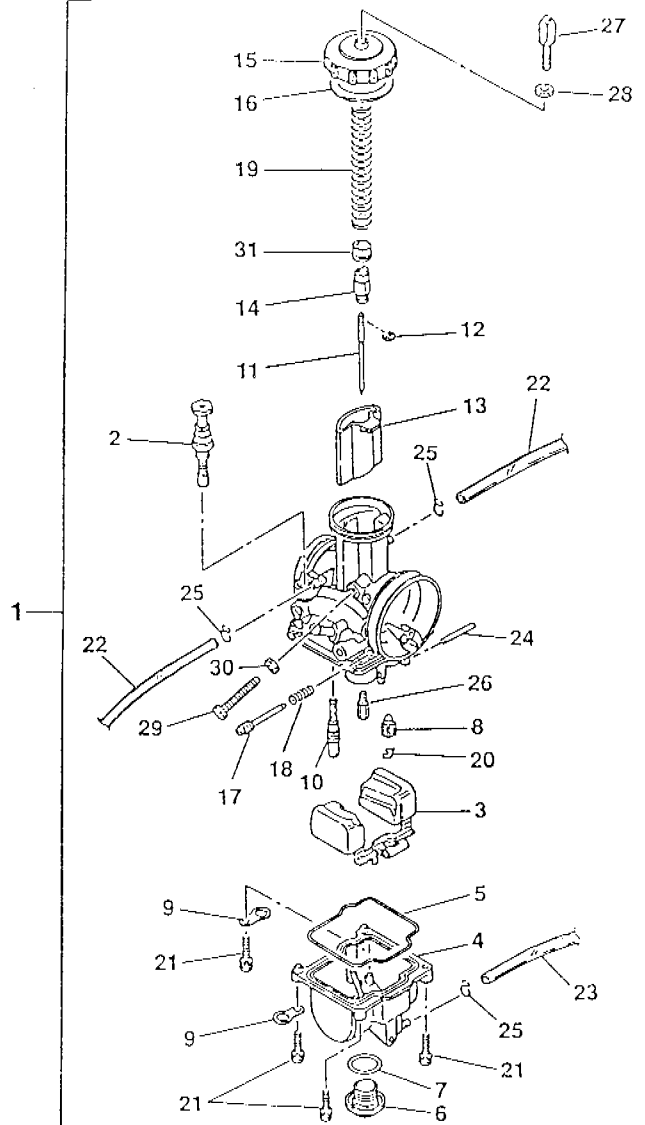
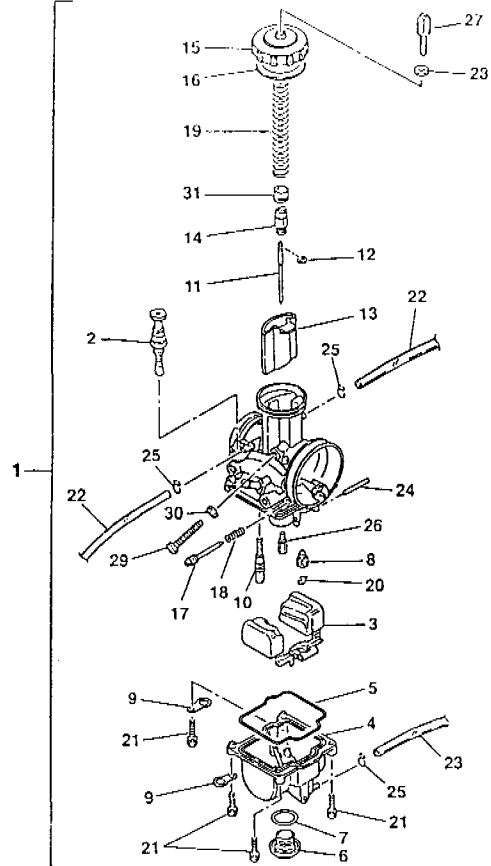

94-565.31.5 ZÜNDAN.MOTOPL. 440SX,550MX'94  
IGNITION SYSTEM

BILD FIG.	TEILENUMMER PART NUMBER	BEZEICHUNG DESCRIPTION	STK. QTY.
2	560.31.002.000	ZÜNDANLAGE MOTOPLAT 9600 176-1 IGN.WITHOUT COIL	1
3	570.13.070.100	SCHELLE 5/16" SCHWARZ CLAMP	1
4	510.31.004.000	KABELDURCHFÜHRUNG RUBBER GROMMET	1
5	510.31.005.000	STECKVERBINDER KLEIN RECEPTACLE SMALL	1
6	510.31.006.200	ZÜNDSPULE IGNITION COIL	1
10	545.31.010.000	KERZENSTECKER LB05EMH NGK SPARK PLUG PROTECT	1
11	510.31.011.000	STECKVERBINDER GROSS RECEPTACLE, LARGE	1
93*	560.31.093.340	ZÜNDKERZE NGK-B85-EGV 440/550 SPARK PLUG	1
94	0933 060163	SK-SCHRAUBE DIN933-M6X16 H H SCREW	2
95	0021 060003	SCHEIBE DIN9021-A6,4 FLAT WASHER	2
96	0985 060003	SS-MUTTER DIN985-M6 S L NUT	2
97	0085 040203	PANHEADSCHRAUBE DIN85-M4X20 PAN HEAD SCREW	3
98	0084 050123	ZYLINDERSCHRAUBE DIN84-M5X12 FILIST.HEAD SCREW	1
99	0137 040003	FEDERSCHEIBE DIN137-B4 SPRING WASHER	3
100	0084 050123	ZYLINDERSCHRAUBE DIN84-M5X12 FILIST.HEAD SCREW	3
101	0125 050003	SCHEIBE DIN125-A5,3 FLAT WASHER	4

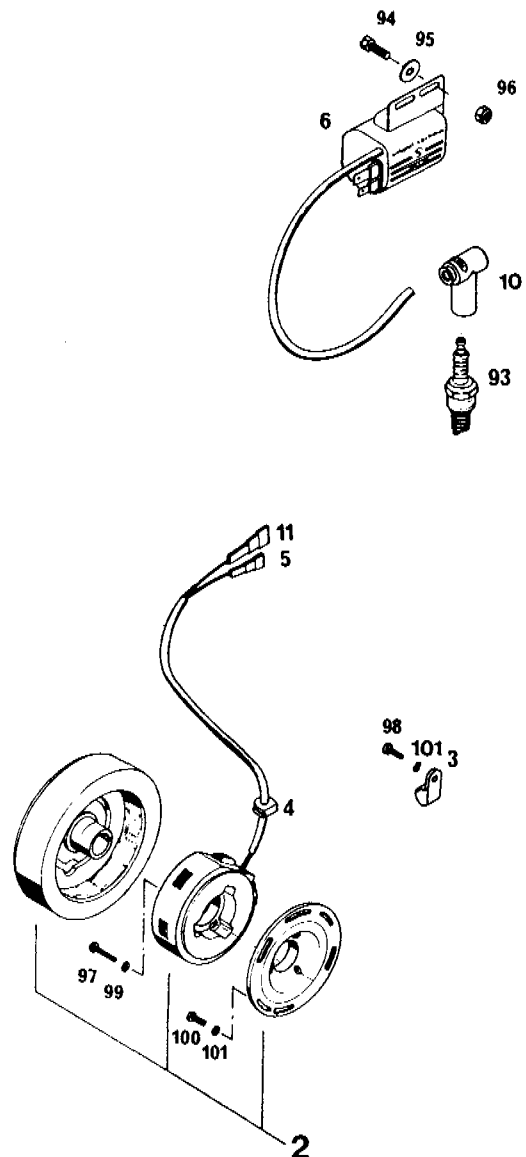

94-565.31.6 ZÜNDANLAGE SEM 440 MXC/EXC '94  
IGNITION SYSTEM

BILD FIG.	TEILENUMMER PART NUMBER	BEZEICHNUNG DESCRIPTION	STK. QTY.
2B*	565.31.002.000	ZÜNDANLAGE SEM K10/60 EG 13 IGNITION CPL.	1
6*	545.31.006.000	ZÜNDSPULE TM 11-09 IGNITION COIL	1
7	0085 050303	PANHEADSCHRAUBE DIN85-M5X30 PAN HEAD SCREW	3
8	0125 050003	SCHEIBE DIN125-A5,3 FLAT WASHER	3
9	0084 050123	ZYLINDERSCHRAUBE DIN84-M5X12 FILIST.HEAD SCREW	3
10	0125 050003	SCHEIBE DIN125-A5,3 FLAT WASHER	4
11	0912 050123	ISK-SCHRAUBE DIN912-M5X12 A H SCREW	1
22	545.31.010.000	KERZENSTECKER LB05EMH NGK SPARK PLUG PROTECT	1
62	0931 060453	SK-SCHRAUBE DIN931-M6X45 H H SCREW	2
63	120.11.016.000	SCHEIBE 6 X 12 X 3 WASHER	2
64	0125 060003	SCHEIBE DIN125-A6,4 FLAT WASHER	2
65	0985 060003	SS-MUTTER DIN985-M6 S L NUT	2
70	570.13.070.000	SCHELLE 7/16" CLAMP	1
71	500.31.003.000	HALTEPLÄTTCHEN RETAINING PLATE	1
93	560.31.093.340	ZÜNDKERZE NGK-B85-EGV 440/550 SPARK PLUG	1

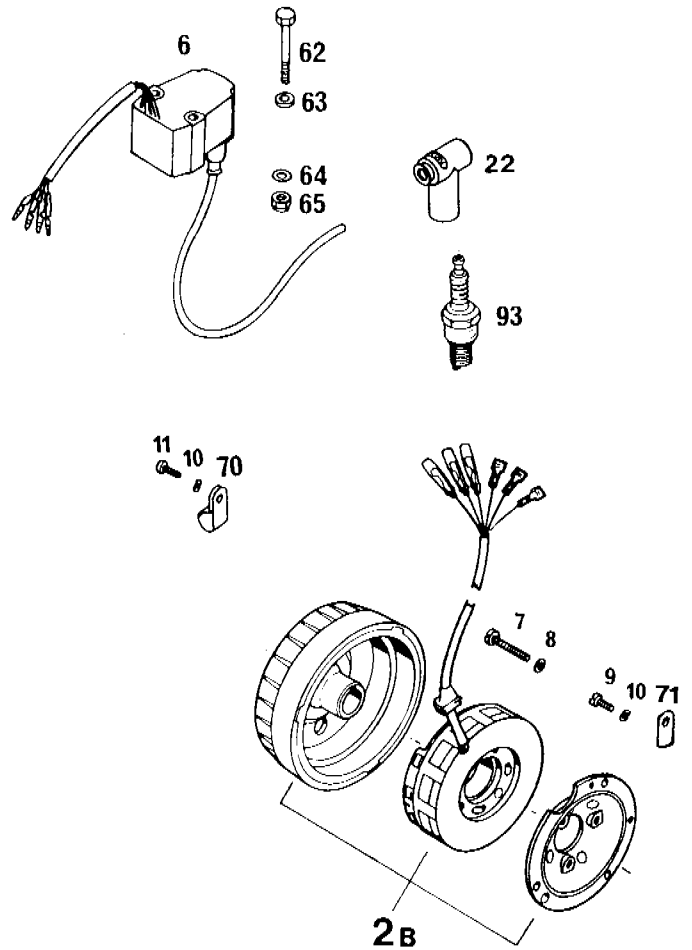

94-565.32.1 KUPPLUNG 440/550 '94  
CLUTCH

BILD FIG.	TEILENUMMER PART NUMBER	BEZEICHNUNG DESCRIPTION	STK. QTY.
1	565.32.101.344	KUPPLUNGSKORB 76-Z M.PRIM.29-Z OUTER CLUTCH HUB	1
2	580.32.001.000	KUPPLUNGSKORB LOSE OUTER CL.HUB LOOSE	1
3	580.32.007.000	NIET DIN 7338 8 X 11,2 RIVET	6
4	565.32.012.000	ANLAUFSCHEIBE 22,2 X 35 X 2 THRUST WASHER	2
5	565.32.096.000	INNENRING 22 X 26 X 22 INNER BUSHING	1
6	565.32.095.000	NADELKÄFIG K 26 X 30 X 22 NEEDLE CAGE	1
7	580.32.012.500	STAHLLELLE 2 MM STEEL DISC	2
8	580.32.012.000	STAHLLELLE 1 MM CLUTCH DISC	8
9	565.32.011.300	SINTERLELLE 2 MM CLUTCH DISC	9
10	565.32.002.100	MITNEHMER 440/500 INNER CLUTCH HUB	1
10	565.32.002.400	MITNEHMER 550 INNER CLUTCH HUB	1
11	565.32.018.000	SICHERUNGSBLECH FLAT WASHER	1
12	0936 181505	SK-MUTTER DIN936-M18X1,5 - 8.8 HEX NUT	1
13	565.32.003.500	DRUCKKAPPE '88 ABGEDREHT PRESSURE PLATE	1
13*	565.32.003.100	DRUCKKAPPE PRESSURE PLATE	1
14	543.32.001.000	KUPL.DRUCKFEDER 2,5 X 38 (7W) CLUTCH SPRING	6
14	544.32.001.100	DRUCKFEDER 2,7 X 38 CLUTCH SPRING	6
15	0021 060003	SCHEIBE DIN9021-A6,4 FLAT WASHER	6
16	0933 060203	SK-SCHRAUBE DIN933-M6X20 H H SCREW	6
17	545.32.014.000	AUSRÜCKHEBEL DISENGAGING LEVER	1
18	0912 060203	ISK-SCHRAUBE DIN912-M6X20 A H SCREW	1
19	545.32.013.000	HALTEBLECH F.AUSRÜCKUNG RETAINING PLATE	1
20	0991 060122	SENKSCHEIBE DIN7991-M6X12 ALLEN FLATHEAD SCR	2
21	545.32.093.000	NUTRING N 12 X 20 X 5,5 SEAL RING	1
22	545.32.091.000	INNENRING IR 17 X 20 X 30,5 BUSHING	1
23	545.32.090.000	NADELKRANZ 12 X 17 X 13 NEEDLE CAGE	2
24	545.32.015.100	AUSRÜCKWELLE D= 12MM 250/V '87 DISENGAGING SHAFT	1
25	565.32.017.500	DRUCKSTANGE L=188 440/500 PUSH ROD	1



BILD FIG.	TEILENUMMER PART NUMBER	BEZEICHNUNG DESCRIPTION	STK. QTY.
27	543.32.030.000	AXIAL-NADELKRANZ AXK 1024 KPL. AXIAL NEEDLE BEARG	1
28	0471 100010	SEEGERRING DIN471-10X1 CIRCLIP	1

\* = NEUTEILE / NEW PARTS

X = NACH BEDARF / AS REQUIRED

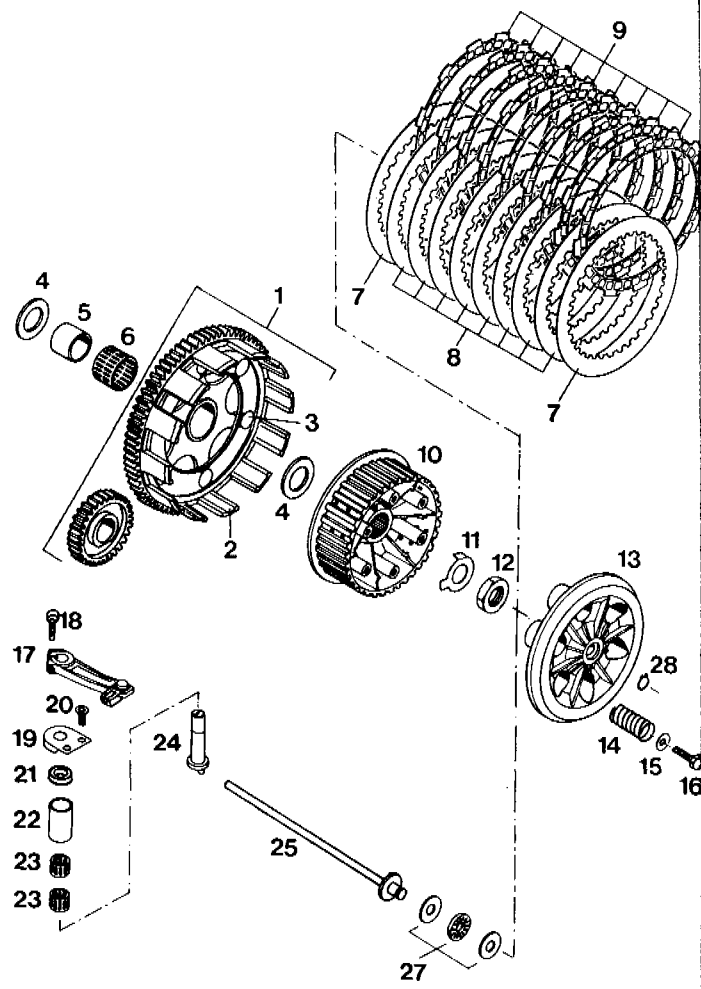

87-555.33.1 KICKSTARTER 440/500/550 '92  
KICKSTARTER

BILD FIG.	TEILENUMMER PART NUMBER	BEZEICHNUNG DESCRIPTION	STK. QTY.
1	565.33.027.000	SPERRADFEDER SPRING	1
2	565.33.023.000	SPERRAD KICKSTART RATCHET	1
3	565.33.021.000	KICKSTARTERWELLE KICKSTARTER SHAFT	1
4	501.33.090.000	SPRENGRING SW22 CIRCLIP	1
5	501.33.015.000	ANLAUFSCHLEIBE 20,9X25,2X1,5 THRUST WASHER	1
6	565.33.022.000	STARTERRAD 34-Z KICKSTARTER GEAR	1
7	565.33.024.000	STARTERZWISCHENRAD 28-Z INTERMEDIATE GEAR	1
8	565.33.026.000	MITNEHMERNABE WASHER	1
9	565.33.020.500	KICKSTARTERFEDER KICKSTARTER SPRING	1
10	565.33.036.244	KICKSTARTER KPL. KICKSTARTER 500/87 440/500/550	'87 1

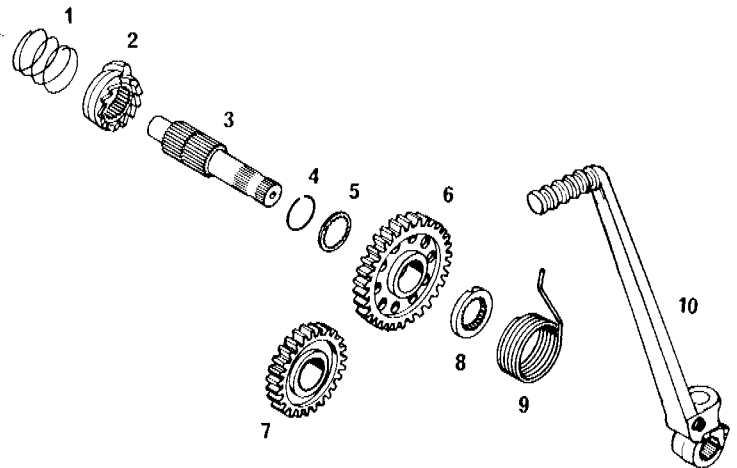

\* = NEUTEILE / NEW PARTS X = NACH BEDARF / AS REQUIRED

94-565.33.2 GETRIEBE I 440/550 '94  
TRANSMISSION I

BILD FIG.	TEILENUMMER PART NUMBER	BEZEICHNUNG DESCRIPTION	STK. QTY.
1*	575.33.002.000	ANTRIEBSWELLE 15Z MAIN SHAFT	'93 1
2	565.33.110.400	FESTRAD 2.G 16 Z (2M4) 2ND G. MAINSHAFT	1
3	565.33.004.300	LOS RAD 3.G 18 Z (3M3) 3RD GEAR COUNTERS.	1
4	565.33.006.300	SCHIEBERAD 4.G 20 Z (4M3) 4TH GEAR MAINSHAFT	1
5	565.33.008.300	LOS RAD 5.G 27 Z (5M3) 5TH GEAR COUNTERS.	1
6	565.33.016.300	ANLAUFSCHLEIBE 22,7 X 32 X 1,5 THRUST WASHER	2
8	565.33.015.000	ANLAUFSCHLEIBE 20,2 X 35 X 1 THRUST WASHER	1
9	565.33.099.000	NADELKÄFIG K22X26X13 GETEILT NEEDLE CAGE	2
10	520.33.096.000	SPRENGRING 25 X 1,6 CIRCLIP	2
11	0625 201029	RILLENKUGELLAGER 6304/22/C4QE6 BALL BEARING	1
12	565.33.093.000	NADELLAGER RNA 4902 KSE NEEDLE BEARING	1

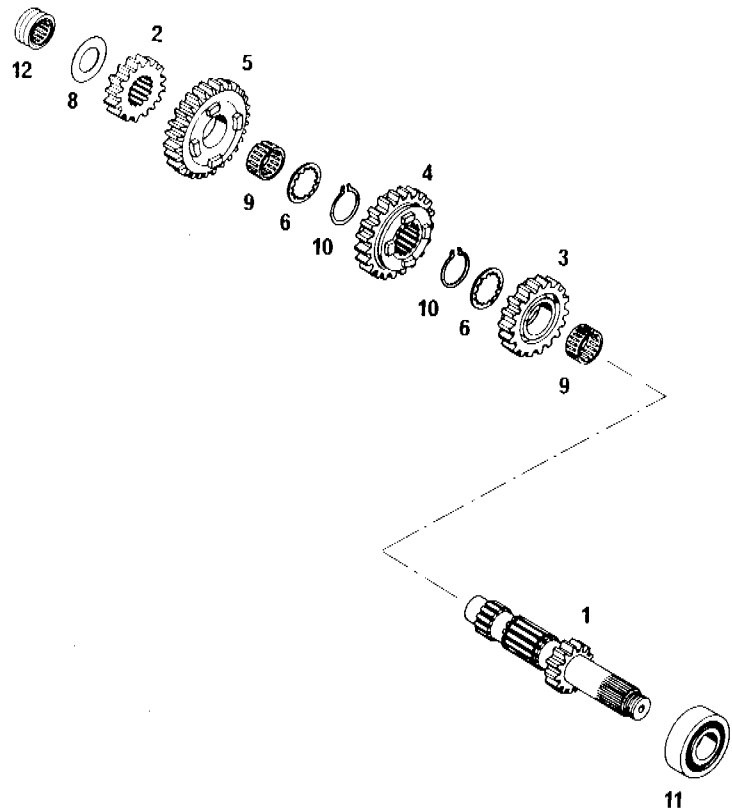

\* = NEUTEILE / NEW PARTS X = NACH BEDARF / AS REQUIRED

94-565.33.3 GETRIEBE II 440/550 '94  
TRANSMISSION II

BILD FIG.	TEILENUMMER PART NUMBER	BEZEICHNUNG DESCRIPTION	STK. QTY.
0	565.33.019.000	DISTANZRING SPACER RING	1
1*	575.33.005.000	4-GANG/4-SPEED LOSRAD 1.G 33 Z (1M4) 1ST GEAR COUNTERS.	'93 1
2	565.33.013.400	5-GANG/5-SPEED LOSRAD 2.G 24 Z (2M4) 2ND GEAR COUNTERS.	1
3	565.33.007.300	SCHIEBERAD 3.G 21 Z (3M3) 3RD GEAR COUNTERS.	1
4	565.33.009.300	LOSRAD 4.G 19 Z (4M3) 4TH GEAR MAINSH.	1
5	565.33.011.300	SCHIEBERAD 5.G 21 Z (5M3) 5TH GEAR COUNTERS.	1
6	565.33.003.300	ABTRIEBSWELLE COUNTERSHAFT	1
7	500.33.001.000	VERSCHLUSSPFROPFEN PLASTIC CAP	1
8	565.33.015.000	ANLAUFSCHEIBE 20,2 X 35 X 1 THRUST WASHER	1
9	565.33.018.300	ANLAUFSCHEIBE 22,2 X 35 X 1,5 THRUST WASHER	1
10	565.33.016.300	5-GANG/5-SPEED ANLAUFSCHEIBE 22,7 X 32 X 1,5 THRUST WASHER	1
12	520.33.096.000	SPRENGRING 25 X 1,6 CIRCLIP	4
15	565.33.099.000	NADELKÄFIG K22X26X13 GETEILT NEEDLE CAGE	2
015	565.33.098.000	NADELKÄFIG K 22 X 26 X 13 NEEDLE CAGE	1
16	565.33.093.000	5-GANG/5-SPEED NADELLAGER RNA 4902 KSE NEEDLE BEARING	1
17	0625 062059	FÜLLNUTENLAGER 205 R 20.30 BEARING	1
18	560.33.020.000	ANLAUFRING THRUST WASHER	1
19	0770 020220	O-RING 2-022 1,78X25,12X28,68 O-RING	1
20	501.33.018.000	DISTANZBÜCHSE 25X32X12,7 BUSHING	1
21	0760 324770	WELLENDICHTRING 32X47X7B SEAL RING	1
22	500.33.029.014	KETTENRAD 5/8X1/4" 14-Z SPROCKET 14-T	1
22	500.33.029.013	440 MXC, EXC / 550 MXC KETTENRAD 5/8X1/4" 13-Z SPROCKET 13-T	1
		440 SX	

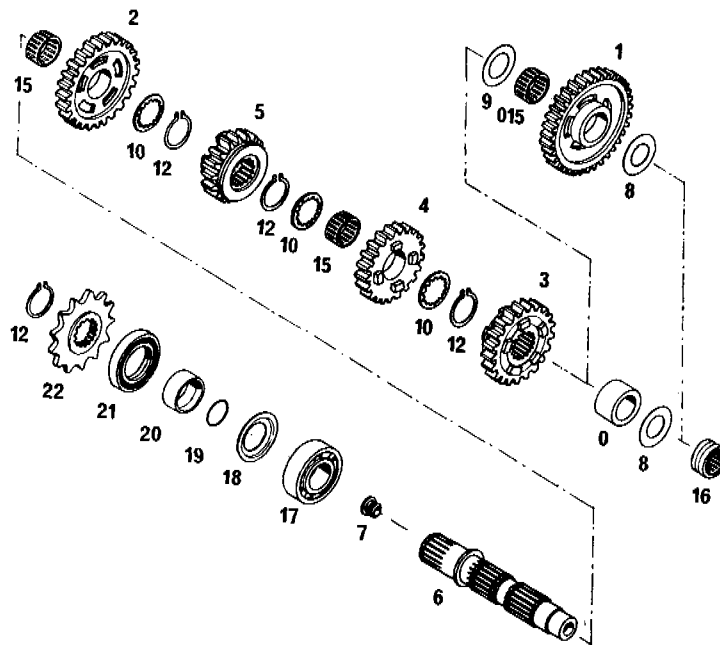

94-565.34.0

SCHALTUNG 440/550  
SHIFTING MECHANISM

'94

BILD FIG.	TEILENUMMER PART NUMBER	BEZEICHNUNG DESCRIPTION	STK. QTY.
1	565.34.014.200	RÜCKHOLFEDER SPRING	1
2	565.34.020.000	ABDECKRING COVER RING	1
3	565.34.007.200	SCHALTSTÜCK SHIFTING QUADRANT	1
4	565.34.008.200	GLEITBLECH SLIDING COMPONENT	1
5	565.34.013.100	SPANNFEDER SPRING	1
6	565.34.005.100	SCHALTWELLE SHIFTING SHAFT	1
7	565.30.026.100	PASSSCHEIBE 30/14/1,5 FLAT WASHER	1
8	565.34.022.000	SCHALTHEBEL ALU SHIFTING LEVER	1
10*	580.34.002.200	SCHALTGABEL 1./4. U.2.G. SHIFT FORK 1/4 + 2	2
11	565.34.004.300	SCHALTSCHIENE 1/4 U 2 G SHIFTING ROD	1
12	580.34.001.100	SCHALTGABEL 3./5. GANG SHIFT.FORK 3RD/5TH	1
13	565.34.003.300	SCHALTSCHIENE 3/5 G SHIFTING ROD	1
14	0799 080000	SICHERUNGSSCHEIBE DIN6799-RS8 RETAINING CLIP	1
15*	565.34.024.044	ARRETIERHEBEL KPL. LOCATING LEVER CPL	1
16	565.34.023.000	ARRETIERHEBELFEDER SPRING	1
17	502.34.020.000	FEDERBÜCHSE SPRING BUSHING	1
20	565.34.012.500	SCHALTWALZE (STAHL) 440/500'94 SHIFTING DRUM	1
20	565.34.012.300	SCHALTWALZE (STAHL) 550'92 SHIFTING DRUM	1
21	0472 025018	KERBSTIFT 2,5 X 18 DIN 1472 PIN	1
22	501.34.026.000	NADELHÜLSE 30 X 38 X 7,5 NEEDLE CAGE	X
22*	501.34.026.100	NADELHÜLSE 30 X 37 X 7,5 NEEDLE CAGE	1
23A	565.34.015.344	SCHALTARRETIERUNG KPL. 4-GANG SHIFT LOCAT.DRUM	1
23B	565.34.115.344	SCHALTARRETIERUNG KPL. 5-GANG SHIFT LOCAT.DRUM	1
24	565.34.016.000	SENKSCHRAUBE M6X30 SELBSTSICH. COUNTERSUNK SCREW	1
25	580.33.099.000	NADELKÄFIG K 24X30X7,5 DN NEEDLE CAGE 440/500	1

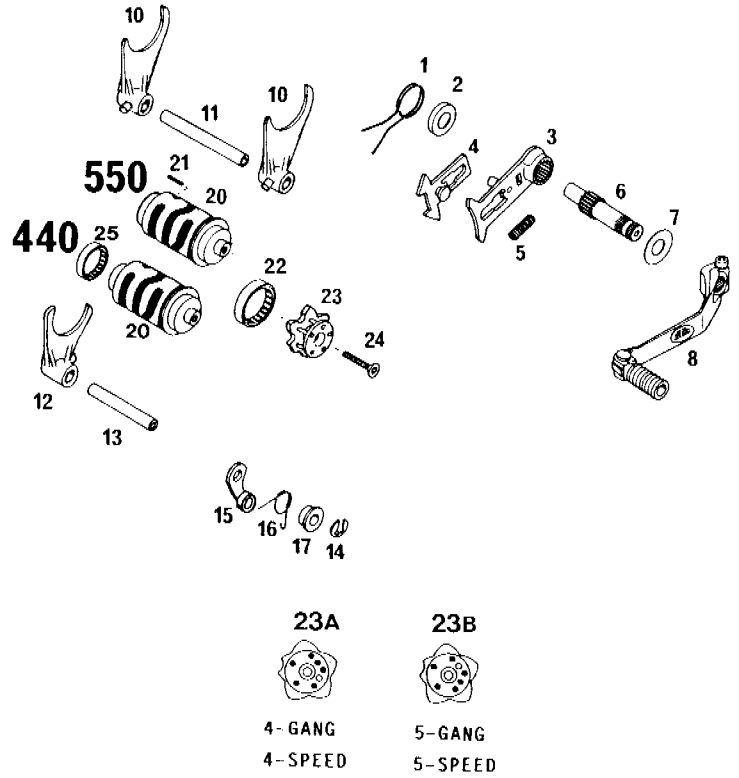

\* = NEUTEILE / NEW PARTS

X = NACH BEDARF / AS REQUIRED

94-565.35.0 KÜHLSYSTEM 440/550 '94  
COOLING SYSTEM

BILD FIG.	TEILENUMMER PART NUMBER	BEZEICHNUNG DESCRIPTION	STK. QTY.
1	565.35.008.500	KÜHLER RECHTS RADIATOR R/S 440/500/550	(4 5145) 1
2	580.35.016.000	KÜHLERVERSCHLUSS KLEIN 1,4 BAR RADIATOR CAP	1
3	565.35.007.500	KÜHLER LINKS RADIATOR L/S 440/500/550	(4 5146) 1
4	565.35.034.500	KÜHLERSCHUTZ RE/LI PROTECTOR	'92 2
6	502.35.033.300	KLIPS-MUTTERNHALTER M6 KP142 SNAP NUT	4
8*	580.35.026.000	T-STÜCK 19/19/19 T-CONNECTOR	1
9*	546.35.013.044	THERMOSTATGEH. KPL. 55 GRAD'94 THERMOSTAT HOUSING	1
10	565.35.025.001	KÜHLERSCHLAUCH 18X25 PER MET. RADIATOR HOSE	0,10
11	565.35.025.000	KÜHLER-FORMSCHLAUCH 18 X 25 PREF.RAD.HOSE	1
12	100.01.020.000	SCHLAUCHBINDER A2 CLAMP	10
13	544.35.024.001	ND-SCHLAUCH ID 7,5 PER METER HOSE	0,18
14	544.35.023.100	PVC-SCHELLE NR.4 PVC CLAMP	2
15	550.07.016.001	SCHLAUCH 7X10 PER METER HOSE 7X10	0,45
16	440.11.076.155	KABELBAND 155MM PLASTIC BAND	X
20	410.01.052.000	KABELTÜLLE (INNENDURCHM.11MM) RUBBER SLEEVE	6
21	0021 060003	SCHEIBE DIN9021-A6,4 FLAT WASHER	6
23	0912 060253	ISK-SCHRAUBE DIN912-M6X25 A H SCREW	4
23	0912 060123	ISK-SCHRAUBE DIN912-M6X12 A H BOLT	2
24	565.35.035.000	BÜCHSE 6,5 X 12 X 9 BUSHING	4
25	546.03.048.100	MEHRBEREICHBLECHMUTTER M6 SHEET-METAL NUT	4
30*	546.35.017.000	THERMOSTAT 55 GRAD THERMOSTAT	'94 1
31*	0770 320020	O-RING 32 X 2 O-RING	2
32*	580.35.025.900	FORMSCHLAUCH 18 X 24 - 90GRAD PREF.RAD.HOSE	X
35	544.35.025.000	FORMSCHLAUCH 18 X 25 - 130GRAD PREF.RAD.HOSE	1

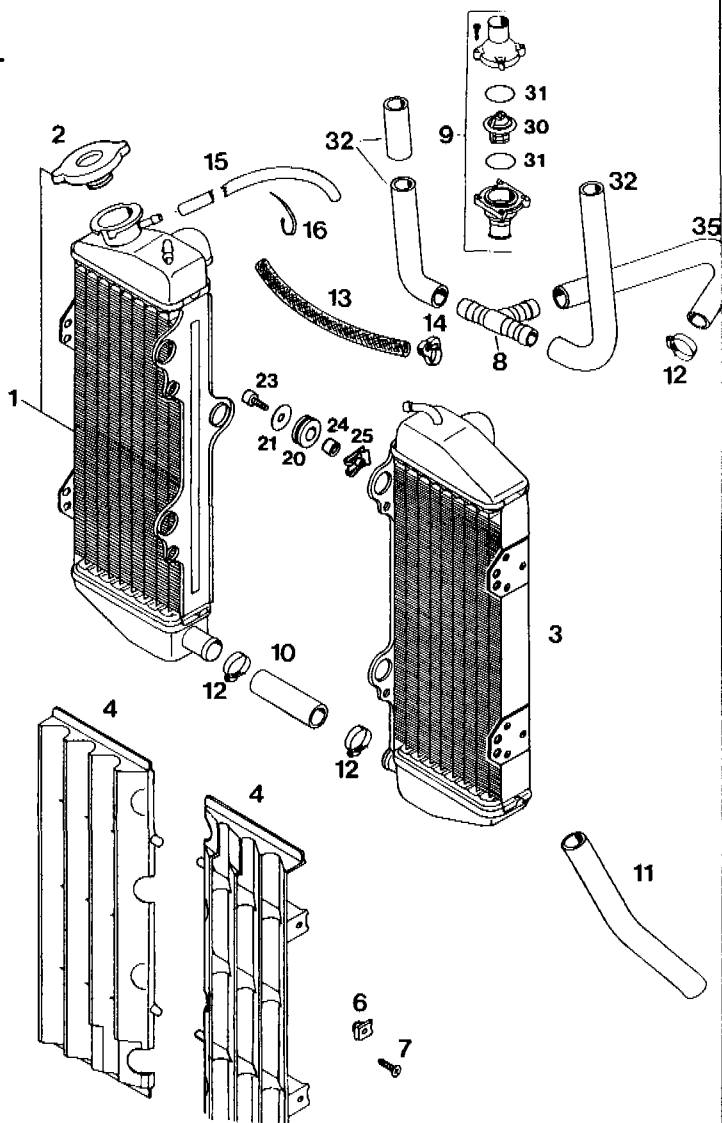

90-555.29.1

SPEZIALWERKZ. 440/500/550 '92  
SPECIAL TOOLS

BILD FIG.	TEILENUMMER PART NUMBER	BEZEICHNUNG DESCRIPTION	STK. QTY.
1	560.12.001.000	AUFSPANNBOCK REPAIR STAND	1
2	565.12.001.050	MOTORHALTER ENG.MOUNT BRACKET	1
3	580.12.003.000	KÜPPLUNGSHALTER 250-612 HOLDING PLATE	1
4	565.12.004.000	PRIMÄRZAHNRADHALTER HOLDING PLATE	1
6	565.12.005.014	FÜHRUNGSHÜLSE 14MM (F.SIMMERR) GUIDE SLEEVE	1
7	565.12.005.017	FÜHRUNGSHÜLSE 17MM (F.SIMMERR) GUIDE SLEEVE	1
8	565.12.005.032	EINZIEHHÜLSE 32 MM GUIDE SLEEVE	1
9	6276 807	MAGNETABZIEHER M26X1,5 SEM PULLER F. FLYWHEEL	1
10	510.12.011.000	SEEGERRINGZANGE VERKEHRT SPEC.CIRCLIP PLIER	1
11	501.12.013.000	MESSUHR 0-10 MM DIAL GAUGE	1
12	510.12.014.000	GRADSCHIEBE TIMING DEGREE DISC	1
13	510.12.016.000	SCHUTZKAPPE PROTECTION CAP	1
14	544.12.012.000	HALTESCHLÜSSEL F.SCHWUNGRAD HOLD.SPANNER FLYWH	1
15	580.12.021.000	ABZIEHER EXTRACTOR	1
16	501.12.030.000	MESSUHRHALTER DIAL GAUGE SUPPORT	1
17	151.12.017.000	LAGERAUSZIEHER BEARING EXTRACTOR	1
18	151.12.018.100	EINSATZ 18-23 MM INTERN.BEAR.PULLER	1
21	6899 785	LOCTITE BLAU 242 LOCTITE BLUE	6 CCM X

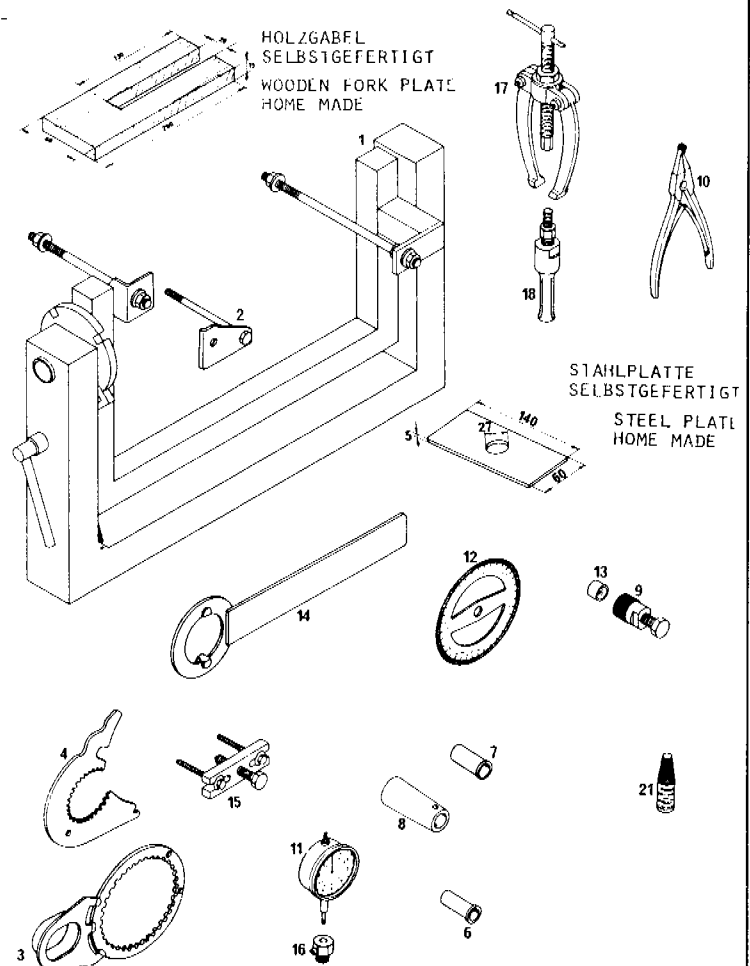

# TECHNISCHE DATEN - MOTOR

Motor	440 SX	440 EXC, MXC	550 MXC
Bauart	Flüssigkeitsgekühlter Einzylinder-Zweitakt-Ottomotor mit Membraneinlaß (550 mit PAS-System)		
Hubraum	435,25 cm <sup>3</sup>	547,80 cm <sup>3</sup>	
Bohrung/Hub	89/70 mm	92,25/82 mm	
Kraftstoff	Superkraftstoff ROZ 95, mit Zweitaktöl gemischt		
Mischungsverhältnis	1:40 - 1:50 bei Verwendung von hochwertigen Zweitaktölen. Im Zweifelsfall setzen Sie sich bitte mit Ihrem Importeur in Verbindung oder mischen Sie vorsichtshalber 1:30		
Kurbelwellenlagerung	2 Zylinderrollenlager		
Pleuellager	Nadellager		
Kolbenbolzenlager	Nadellager		
Kolben	Leichtmetall - geschmiedet		
Kolbenring	2 Rechteckringe		
Maß "X" <small>(Mehrschichtmetall-Zylinderbohrung)</small>	1,0 - 1,1 mm	1,25 - 1,35 mm	
Zündzeitpunkt	1,8 mm (16,5 Grad) vor OT	2,15 mm (16,5 Grad) vor OT	
Zündkerze	NGK B85 EGV		
Elektrodenabstand	0,6 mm		
Primärtrieb	Gerade verzahnte Stirnräder, Primärübersetzung 29 : 76		
Kupplung	Mehrscheibenkupplung im Ölbad		
Getriebe	Klauengeschaltetes 4- bzw. 5-Gang-Getriebe		
Getriebeübersetzung	siehe Tabelle 2		
Getriebeschmierung	0,8 l Motoröl SAE 30		
Kühlfähigkeit	1,3 Liter, Mischungsverhältnis 40% Frostschutz, 60% Wasser, mindestens -25° C		
Zündanlage	Motoplatt 9600 176-1	SEM K10 60 EG 13	Motoplatt 9600 176-1
Generatorleistung	kein Generator	12V 130W	kein Generator
Vergaser	Flachschieber-Vergaser, Einstellung siehe Tabelle 3		
Luftfilter	Schaumstoff-Naßluftfilter-Einsatz		

## VERGASER-GRUNDEINSTELLUNG

	440 SX Europa 440 EXC E	440 EXC USA 440 MXC	550 MXC USA
Vergasertyp	Keihin PWK 39	Keihin PWK 39	Keihin PWK 39
Hauptdüse	180 (185)	185 (180/190)	185 (180, 190)
Leerlaufdüse	45 (48, 50)	52 (50, 55)	50 (48, 52)
Startdüse	85	85	85
Düsenmadel	R 1368 J (R 1366 J)	R 1466 J (R 1465 J)	R 1363 N
Nadelposition von oben	II	II	III
Schieber	6	6	6
Luftregulierschraube offen	1,5	1,5	1,5

## GETRIEBEÜBERSETZUNG

Primär- über- setzung	Getriebeübersetzung	Original- übersetzung Hinterrad	Lieferbare Kettentritzel	Lieferbare Ketten- räder hinten
29:76	SX	SX	13 Z	45 Z
	E-XC	EXC	14 Z für Kette	48 Z
	MXC	MXC	15 Z $\frac{5}{8} \times \frac{1}{4}$ "	50 Z $\frac{5}{8} \times \frac{1}{4}$ "
	-	-	16 Z	52 Z
	1. Gang	16:24	16:24	
2. Gang	18:21	18:21		
3. Gang	20:19	20:19		
4. Gang	27:21	27:21		
5. Gang				

## Toleranzen-Einbauspiele

Kolbeneinbauspil	440: 0,050 - 0,060 mm 550: 0,055 - 0,065 mm	
Kolbenring - Stoßspiel	0,2 - max. 0,6 mm	
Pleuellager - Radialspiel	0,035-0,046 mm max. 0,065 mm	
Getriebewellen - Axialspiel	0,2-0,4 mm	
Kupplungsdruckfedern - Länge	440: Ø 2,5 mm, L = 38 mm 550: Ø 2,7 mm, L = 38 mm	
<b>Dichtungsstärken</b>		
Motorgehäuse	0,3 mm	
Kupplungsdeckel	0,75 mm	
Zündungsdeckel	1,5 mm	
Zylinderfußblechung	nach Bedarf	
Lieferbare Fußdichtungen	0,2/0,3/0,5 mm	
Wasserraumdichtung	0,2 mm	
<b>Anzugsdrehmomente</b>		
Bundschrauben-Zylinderkopf	M 8	34 Nm
Bundmutter-Zylinderfuß	M 10	34 Nm
Bundmutter-Schwungrad	M 12x1	59 Nm
Mutter für Primärrad	M 20x1,5	98 Nm
Mutter für Kupplungsminehmer	M 18x1,5	98 Nm
Motorgehäuse und Deckelschrauben	M 6	8 Nm
Schwingarmbolzen	M 14	137 Nm
Steckachse hinten	M 20x1,5	88 Nm
Restliche Schrauben	M 6 M 8 M 10	5 Nm 29 Nm 49 Nm

## TECHNICAL DATA - ENGINE

Engine	440 SX	440 EXC, MXC	550 MXC
Design	Liquid-cooled single-cylinder two-stroke engine with reed induction (550 with PAS-system)		
Piston displacement	435,25 ccm	547,80 ccm	
Bore/stroke	89/70 mm	92,25/92 mm	
Fuel	SUPER fuel, research octane no 95, mixed with two stroke oil		
Oil/gasolin ratio	1:40-1:50 when using high grade two stroke oil. When in doubt, please contact your importer or use 1:30 mix ratio to be on the safe side		
Crankshaft bearing	2 cylindrical roller bearings		
Connecting rod bearing	needle bearing		
Piston pin bushing	needle bearing		
Piston	light alloy, forged		
Piston ring	2 plain compression rings		
Dimension "X" <small>(distance between roller centers - inner roller centers)</small>	1,0 - 1,1 mm		1,25 - 1,35 mm
Ignition timing	1,8 mm (16,5°) BTDC		2,15 mm (16,5°) BTDC
Spark plug	NGK B85 EGV		
Electrode gap	0,6 mm		
Primary drive	straight cut spur gears, primary ratio 29:76		
Clutch	multiple disc clutch in oil bath		
Transmission	4 or 5 speed, claw actuated		
Gear ratios	see Table 2		
Gear lubrication	0,8 l engine oil SAE 30		
Coolant	1,3 litres, 40% anti freeze, 60% water, at least -25° C (-13° F)		
Ignition system	Motoplaf 9600 176-1	SEM K10 60EG 13	Motoplaf 9600 176-1
Generator output	no generator	12V 130W	no generator
Carburetor	flat-slide carburetor, carburetor setting see Table 3		
Air filter	wet foam type air filter insert		

## BASIC CARBURETOR SETTING

	440 SX Europe 440 EXC E	440 EXC USA 440 MXC	550 MXC USA
Carburetor	Keihin PWK 39	Keihin PWK 39	Keihin PWK 39
Main jet	180 (185)	185 (180/190)	185 (180, 190)
Idling jet	45 (48, 50)	52 (50, 55)	50 (48, 52)
Starting jet	85	85	85
Jetneedle	R 1368 J (R 1366 J)	R 1466 J (R 1465 J)	R 1363 N
Needle position from top	II	II	III
Throttle valve	6	6	6
Air adjustment screw open	1,5	1,5	1,5

TABLE 3

## GEAR RATIOS

Primary ratio	Transmission	Original final drive ratio	Available chain drive sprockets	Available final drive sprockets
29:76	E-XC MXC	SX 13:50 EXC 14:50 MXC 14:50	13 teeth 14 teeth for chain 15 teeth $\frac{5}{8} \times \frac{1}{4}$ " 16 teeth	45 teeth 48 teeth for chain 50 teeth $\frac{5}{8} \times \frac{1}{4}$ " 52 teeth
	SX			
	1. Gear 15:33			
	2. Gear 16:24			
	3. Gear 18:21			
4. Gear 20:19				
5. Gear 27:21				

TABLE 2

## Tolerances and fitting clearances

Piston fitting clearance	440: 0,050 - 0,060 mm 550: 0,055 - 0,065 mm
Piston ring - end gap	0,2 - max. 0,6 mm
Connecting rod bearing - radial clearance	0,035 - 0,046 mm max. 0,065 mm
Transmission shaft - end float	0,2 - 0,4 mm
Clutch springs - length	440: $\varnothing 2,5$ mm, L = 38 mm 550: $\varnothing 2,7$ mm, L = 38 mm

## Gasket thicknesses

Crankcase	0,3 mm
Clutch cover	0,75 mm
Ignition cover	1,5 mm
Cylinder bottom gasket	as required
Available bottom gaskets	0,2/0,3/0,5 mm
Cylinder-head gasket	0,2 mm

## Tightening torques

Flange bolts - cylinder-head	M 8	34 Nm
Nuts-cylinder base	M 10	34 Nm
Flywheel collar nut	M 12x1	59 Nm
Nut for primary sprocket	M 20x1,5	98 Nm
Nut for inner clutch hub	M 18x1,5	98 Nm
Crankcase and cover bolts	M 6	8 Nm
Swing arm pivot	M 14	137 Nm
Axle for rear hub	M 20x1,5	88 Nm
Other screws	M 6 M 8 M 10	5 Nm 29 Nm 49 Nm

(Nip x 0,738 = R-153)

KTM-SPORTMOTORCYCLE GESELLSCHAFT M.B.H.  
A-5230 Mattighofen • Postfach 66 • Austria  
Tel. 07742/3152-0 • Telefax 07742/3152-7  
HRB 751 - Handelsgericht Ried im Innkreis